

RD #1005 Static Mixer

Application: STATIC MIXER

Our customer is using numerous heat exchangers for experiments within an R+D pharmaceutical laboratory. They had a requirement for mixing while heat transfer was taking place.

The solution was to partner with a static mixer manufacturer. Using our brazing expertise and shell & tube design, we insert and affixed a static mixer into a $\frac{1}{4}$ " tube.

Solution

- Shell & Tube Heat Exchanger
- Single $\frac{1}{4}$ " tube with static mixer.
- All 316L Stainless Steel with tube stub fittings for welding onto.

Features & Benefits

- Compact design
- High pressure and temp rating
- Full material certification package
- No maintenance

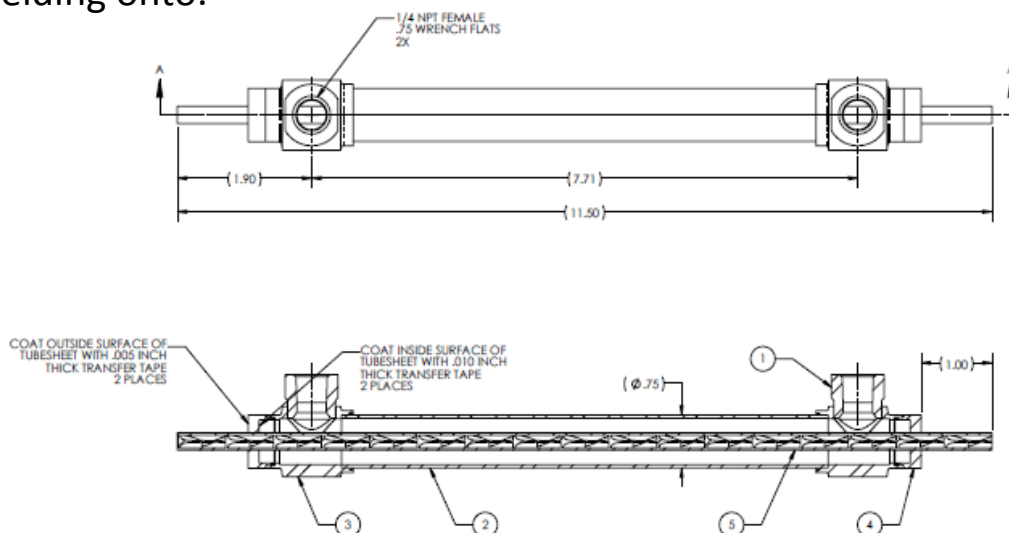

How to contact Exergy

Please call 1-516-832-9300
or visit www.exergyllc.com
to locate your local rep.